

## Comment from iAIRE, LLC

iAIRE imports HVAC condenser units and mini splits from China. Then iAIRE adds a solar panel, sensors, controls, plumbing and electrical to these imported units to allow the solar panel to capture heat from the sun that is used to warm the refrigerant inside of the condenser unit. This additional manufacturing creates a heat pump device that reduces operating expense by up to 50%. This qualifies the product for the solar tax credit of 30% and maybe the Domestic Content increase of another 10%. In calculating the Domestic Content percentage, does the freight to ship the units from China count as foreign content? In calculating the Domestic Content Percentage do duties imposed by the US Customs Department count as foreign content



# Engineering Presentation

- Joe Finkam, PE
- April 21, 2022



- iAIRE is an HVAC manufacturing company focusing on Green products, headquartered in Indianapolis, IN
- Manufacturing is located in Orlando, FL

# What Technologies?

---

- Patented Technologies that include:
- Solar HVAC Units
- Economizers that can reduce the amount of Outside Air while maintaining or improving indoor air conditions and delivering on-going operating utility savings.



- 
- Solar HVAC Split Systems & Packaged RTUs (Commercial/Residential)
  - Dedicated Outside Air and V.A.V. Units
  - Ionization Devices
  - Economizers
  - ERV's
  - Flow Monitoring Equipment
  - Custom Modifications to HVAC units



**SOLAR HVAC – The  
most efficient  
commercial units in  
the market**

The logo for iNIRE features the letters 'i', 'N', 'I', 'R', and 'E' in a bold, black, sans-serif font. The lowercase 'i' has a white dot above it. The uppercase 'N' has a white dot to its left. The uppercase 'I' has a white dot to its left. The uppercase 'R' and 'E' are solid black. The logo is positioned on the right side of the slide against a green background.

**iNIRE**

# Solar HVAC

- Adding a solar panel and variable frequency drive (VFD) to a standard condenser creates a unit that is much more efficient as a unit without the technology



# Solar HVAC Technology

---

- Patented process takes ambient light (doesn't need direct sunlight) around a unit and converts the light to thermal energy (heat)
- Works in a similar format to Solar heating of hot water. The energy from the sun is used to heat the refrigerant in lieu of generating electricity
- The heat added to the refrigerant allows for the compressor to work more efficiently saving electricity





# Solar HVAC Technology

---

- In “Cooling Mode”, the system produces thermal energy to cool a home via ambient thermal energy to raise the temperature of the refrigerant instead of utilizing electricity to operate a compressor
- If the unit is a heat pump: In “Heating Mode”, even at temperatures at and below 20°F, thermal cells increase refrigerant pressure, thereby allowing heating to occur at lower temperatures than normally available with a heat pump. This also lowers the temperatures at which the unit will go into a defrost cycle



# Solar HVAC plumbing schematic

SOLAR HVAC HP PIPING DIAGRAM SCH-0004-P

REVISION: V01.00

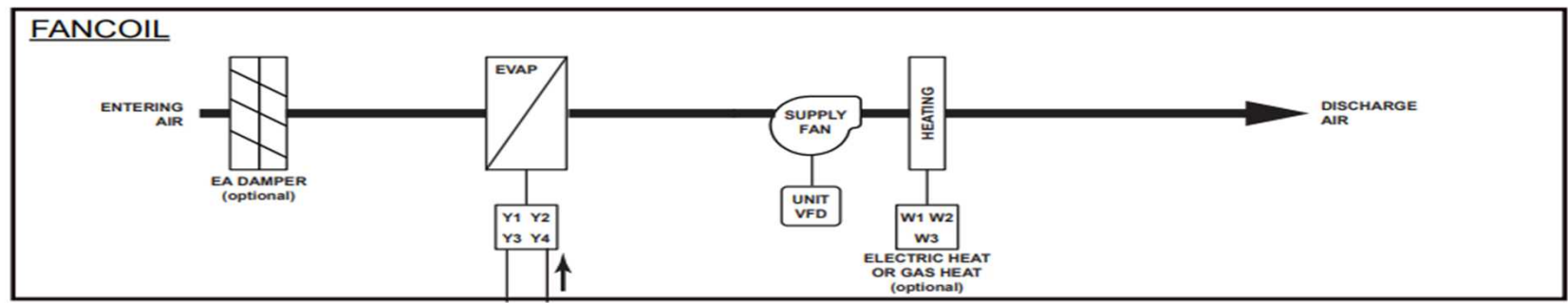

--- FIELD SUPPLIED PLUMBING ON SPLIT SYSTEMS ONLY

← REFGT FLOW DIRECTION FOR HEAT OPERATION

← REFGT FLOW DIRECTION FOR COOLING OPERATION

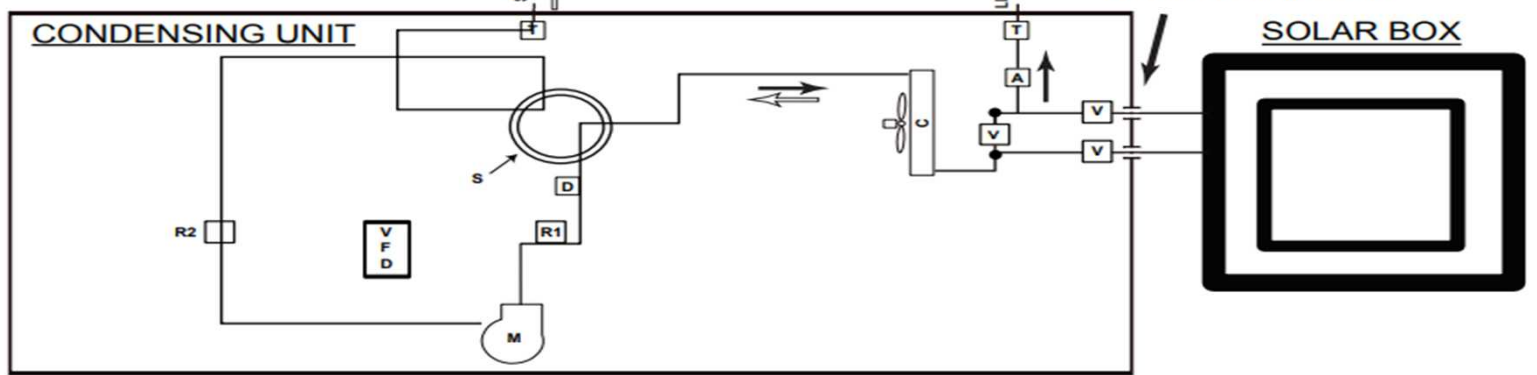

- A - FILTER DRIER
- C - CONDENSER COIL
- M - COMPRESSOR
- Q - LOW-AMBIENT CONTROL OPTION
- R1 - FACTORY HIGH PRESSURE SWITCH (Cooling)
- R2 - FACTORY HIGH PRESSURE SWITCH (Heat)
- S - REVERSING VALVE
- V - VALVE



# Cooling energy savings Indianapolis, In

---

| <u>20 Ton RTU</u> | <u>Unit Type</u>    | <u>Condenser Cooling KWH</u> | <u>% Condenser Savings</u> |
|-------------------|---------------------|------------------------------|----------------------------|
| 10 EER            | Standard Efficiency | 18067                        | 0.0%                       |
| 12 EER            | High Efficiency     | 14502                        | 19.7%                      |
|                   | Solar HVAC          | 7823                         | 56.7%                      |

| <u>5 Ton Res Split</u> | <u>Unit Type</u>      | <u>Condenser Cooling KWH</u> | <u>% Energy Savings</u> |
|------------------------|-----------------------|------------------------------|-------------------------|
| 14                     | Standard Efficiency   | 5583                         | 0.0%                    |
| 17                     | High Efficiency       | 4802                         | 14.0%                   |
| 21                     | Ultra High Efficiency | 4172                         | 25.3%                   |
|                        | Solar HVAC            | 2842                         | 49.1%                   |



# Heat Pump vs gas heat Indianapolis, In

- The next set of data shows the total energy used comparing a gas heat unit versus a heat pump unit
- This data converts gas BTU's to KWH so that there is a direct comparison of energy usage
- The Department of Energy is looking at creating a mandate to utilize heat pumps in lieu of other technology
- California has enacted this mandate starting in 2022



# Heat Pump vw gas heat savings Indianapolis, In

---

| <u>20 Ton RTU</u> | <u>Unit Type</u>    | <u>Cooling KWH</u> | <u>% Cooling Savings</u> | <u>AHU KWH</u> | <u>Heat KWH</u> | <u>Aux Heat</u> | <u>Heat Type</u> | <u>Total Heat</u> | <u>% Heat Savings</u> | <u>Total KWH</u> | <u>% Energy Savings</u> |
|-------------------|---------------------|--------------------|--------------------------|----------------|-----------------|-----------------|------------------|-------------------|-----------------------|------------------|-------------------------|
| 11 EER            | Standard Efficiency | 18067              | 0.0%                     | 19840          | 57921           |                 | Gas              | 57921             | 0.0%                  | 95828            | 0.0%                    |
| 11 EER            | Standard Efficiency | 18067              | 0.0%                     | 19840          | 19991           | 1323            | HP/Elec          | 21314             | 63.2%                 | 59221            | 38.2%                   |
|                   | Solar HVAC          | 7823               | 56.7%                    | 19840          | 8656            | 1323            | HP/Elec          | 9979              | 82.8%                 | 37642            | 60.7%                   |

| <u>5 Ton Res Split</u> | <u>Unit Type</u>    | <u>Cooling KWH</u> | <u>% Cooling Savings</u> | <u>AHU KWH</u> | <u>Heat KWH</u> | <u>Aux Heat</u> | <u>Heat Type</u> | <u>Total Heat</u> | <u>% Heat Savings</u> | <u>Total KWH</u> | <u>% Energy Savings</u> |
|------------------------|---------------------|--------------------|--------------------------|----------------|-----------------|-----------------|------------------|-------------------|-----------------------|------------------|-------------------------|
| 14 SEER                | Standard Efficiency | 5583               | 0.0%                     | 5605           | 8813            |                 | Gas              | 8813              | 0.0%                  | 20001            | 0.0%                    |
| 14 SEER                | Standard Efficiency | 5583               | 0.0%                     | 5605           | 2115            | 219             | HP/Elec          | 2334              | 73.5%                 | 13522            | 32.4%                   |
|                        | Solar HVAC          | 2842               | 49.1%                    | 5605           | 811             | 219             | HP/Elec          | 1030              | 88.3%                 | 9477             | 52.6%                   |



# AHRI Ratings

---

- AHRI ratings are done with both the AHU and the condenser inside a test building (this is to make sure that the temperature and humidity conditions are controlled for testing), since there can be no sunlight on the unit during an AHRI test, the test will produce the same rating with or without the solar panel installation.
- iAIRE's Solar HVAC condenser is rated without the Solar panel to the standard AHRI ratings. This is the number that would be utilized when giving ratings to the authority having jurisdiction when needed.
- iAIRE branded units have an AHRI rating.



# Solar HVAC rating

---

- To receive the tax credits and incentives, units must be Certified to the Solar certification in Standard ICC901/SRCC100. iAIRE's solar panel is certified to be OG-100 rated.
- This certification qualifies the owner to receive any Federal, State, Local or utility company solar rebates, incentives or tax credits



# Solar tax credits and incentives

- Current Federal Solar Tax Credit – 26% on total install
  - Legislation proposed to increase to 30% and extend for 10 years
    - If the solar panel is made in USA (iAIRE's solar panel is) would add 10% making the total credit 40%
    - If the solar panel is used in low-income housing, an additional 20% credit is available
      - This would make iAIRE Solar HVAC used in low-income housing eligible for a 60% Federal Tax Credit
  - Can depreciate almost the balance of the cost in year 1
    - A 26% credit would allow for an 87% 1<sup>st</sup> year depreciation
    - A 40% credit would allow for an 80% 1<sup>st</sup> year depreciation
    - A 60% credit would allow for a 70% 1<sup>st</sup> year depreciation
- State and Local Solar rebates and credits– varies by location
  - Go to <https://www.dsireusa.org/> to look up state and local incentives
  - There are too many to list all
  - Most states are allowing for no sales tax on these system purchases





# How to apply for Solar tax credits

- iAIRE has put together a guide to show how either individuals or companies would get the solar tax credit
- Please go to our website or ask for document MRK-0017 to get this information



## Federal Tax Credit for Solar Installations

### Tax Credit?

A tax credit reduces the amount of income tax liability on a dollar-by-dollar basis. For example, a \$2,000 federal tax credit reduces the federal income taxes due by \$2,000.

### Federal solar tax credit?

The federal solar energy credit is a tax credit that can be claimed on federal income taxes for a percentage of the cost of a solar system.

In December 2020, Congress passed an extension of the Investment Tax Credit ("ITC"), which provides a 26% tax credit for systems installed in 2020 - 2022, and 22% for systems installed in 2023. The tax credit expires starting in 2024 unless Congress renews it. Proposed legislation (Passed by the House and ready for Senate consideration) would increase the credit to 30% and extend the credit for 10 years. It would also increase the solar credit another 10% for solar equipment Built in America (probably more than 55% US content) and would increase the tax credit another 20% for solar equipment installed in low-income housing applications.

There is no maximum amount that can be claimed, and the credit can be carried forward if the credit cannot be completely used in the year the solar equipment is installed.

### Eligibility to claim the federal solar tax credit?

These are the current requirements:

- The solar system was installed before December 31, 2023.
- The solar system is located at your primary or secondary residence in the United States or installed on a commercial facility.
- You own the solar system (i.e., you purchased it with cash or through financing, but you are not leasing the solar equipment).
- The solar system is new or being used for the first time. The credit can only be claimed on the "original installation" of the solar equipment.

### Expenses included in determining Solar equipment "cost"!

The following expenses are included:

- Contractor labor costs for onsite preparation, assembly, or original installation, including inspection costs, and developer fees

# Large Customer Demonstration

For National Accounts and large customers (i.e., national chains, schools or other large customers) that would like to have a trial installation, iAIRE is offering a trial as follows:

- Trial length 1 – 6 months
- Installed on up to (2) units on customer site(s)
- Data collection on these units and additional baseline units
- If trial successful (more than 20% condenser savings) customer will pay for units in demo
- If trial unsuccessful (less than 20% condenser savings) iAIRE will remove the equipment and customer pays nothing



844-348-9168

jlinkam@myaire.com

2100 Consulate Drive, Suite 102  
Orlando, FL 32837

This letter will provide the details on how the iAIRE SOLAR HVAC demonstration program will work for interested customers.

## Purpose of the Program

The purpose of the Solar HVAC demonstration program will be to provide customers with a demonstration of how the system will work with their equipment, at their facility. iAIRE will provide (1) or (2) field installed Solar HVAC kits and installation of these kits to the customer. iAIRE will also provide a monitoring system for these demo units and (1) or (2) other units at the same facility without the solar HVAC. This data can be analyzed to show the reduction in energy consumption that occurs with the SOLAR HVAC product. This demonstration will last from 1 – 6 months based on what the customer would like to see. At the end of the trial, if the Solar HVAC units do not provide any energy savings, iAIRE will remove the Solar HVAC kits and monitoring equipment from the demonstration units and baseline units. The customer will not be charged anything for the demonstration.

If the Solar HVAC units do provide the energy savings to the units, the customer will pay for the price of the demonstration Solar HVAC kits and the kits will remain on the units. The customer will also have the choice to purchase the monitoring equipment or iAIRE will come and remove the monitoring equipment at the end of the demonstration.

The intent of this program is to allow a customer that might not be sure the savings from Solar HVAC are real to see this for themselves at their facilities and then utilize this to help craft a means to start implementation of Solar HVAC with all their HVAC equipment.

## What is included?

-iAIRE will provide (1) or (2) field installed SOLAR HVAC kits for the customers units

-These units will also be outfitted with some control equipment that will monitor the operation of the units

-iAIRE will also provide some monitoring equipment for the units at the same site to compare to the Solar HVAC units

# Effect of alternative refrigerants

- 
- The world is heading towards more environmentally friendly refrigerants
  - Unless the current refrigeration cycle is changed, the new refrigerants will have **no** impact on this technology
    - Units still have a compressor, condenser and evaporator coil
    - Temperatures and pressures will be similar with any potentially new refrigerants



# Competitive Solar Technology

- HVAC units that hook up directly to a solar panel
  - This is not a solar HVAC unit. It is a standard HVAC unit with an adaptor to hook up directly to a DC solar panel.
  - Because of the efficiency of the iAIRE panels, it would take 8 standard solar panels in this scenario to replace the 1 solar panel on an iAIRE 5-ton residential condenser.
  - There is no need for any other work. The solar panel is built into the HVAC unit as opposed to being installed on a roof.
- Solar HVAC with no inverter
  - These units do not have a VFD driven compressor.
    - Makes the unit unable to control the refrigeration cycle when heat is added.
      - Has the ability to burn the refrigerant and run both too hot and too cold on the refrigeration cycle
  - These units cannot work in all states in the continental US
    - iAIRE's unit can work in all 48 states. Only requirement is daylight.



# What Solar HVAC products are offered?

---

- Residential split systems
- Commercial packaged units to 50 tons
- Skids that work with Commercial packaged units to 150 tons
- Commercial split systems to 20 tons
  - These can be combined to get larger tonnage split system offerings
- Dedicated Outdoor Air Systems (DOAS)
  - Packaged units 3 – 150 ton
  - Split systems 6 – 20 tons



# Commercial Solar HVAC Offering

- iAIRE is providing (2) ways to purchase the Solar HVAC
  - As a modification installation in the iAIRE manufacturing facility
  - As an iAIRE field installed modification
- In all cases, the modification would include
  - Solar panel
  - VFD for compressor
  - iAIRE patented economizer controller
- Solar panels are mounted on the condenser end of the unit. Solar panels do not stick up any higher than the current HVAC unit height
- If the modification is installed in the iAIRE manufacturing facility, iAIRE will install the modification onto the unit and test to make sure unit is functional.
- If this is a field modification, the parts will be shipped to the field for installation
- As with all modifications that iAIRE does, there would also be a freight cost on top of the modification cost to get the unit to the jobsite.
- Units are rated to Miami-Dade county wind ratings
  - Units will also meet California seismic



# Commercial Guide Spec

---

- iAIRE has created a guide specification for use with this product
- This is form MKT-0015



## Solar HVAC Commercial Condenser Specification

### Certifications

- Unit should be OG-100 Certified to the Solar certification on ICC901/SRCC100
  - OG-100 Certification will allow the customer to get both Federal and State solar rebates, incentives, and tax credits

### Unit Requirements

- Unit shall be equipped with an OG-100 rated solar panel that is more than 65% effective
- Solar panel is utilized to heat the refrigerant in the circuit in lieu of providing electricity to run the unit
- The solar panel film must be made of a material that utilizes all light rays and can work in indirect sunlight
- Unit must be equipped with a variable frequency driven compressor
- The VFD on the compressor will have a feedback loop that will modulate up and down to keep the pressure in the system operating at normal pressures. On/off compressor operation is not permissible.
- Unit designed to Miami-Dade County wind ratings

# Commercial Submittals

- Currently available on our website
- Available in our on-line quoting/selection software iSELECT
- DOAS submittals with Solar HVAC already available in iSELECT
- Adds to base unit submittal:
  - No additional electrical
  - 100 lbs. weight per 5 tons of solar panel (this includes piping, VFD's & controls)

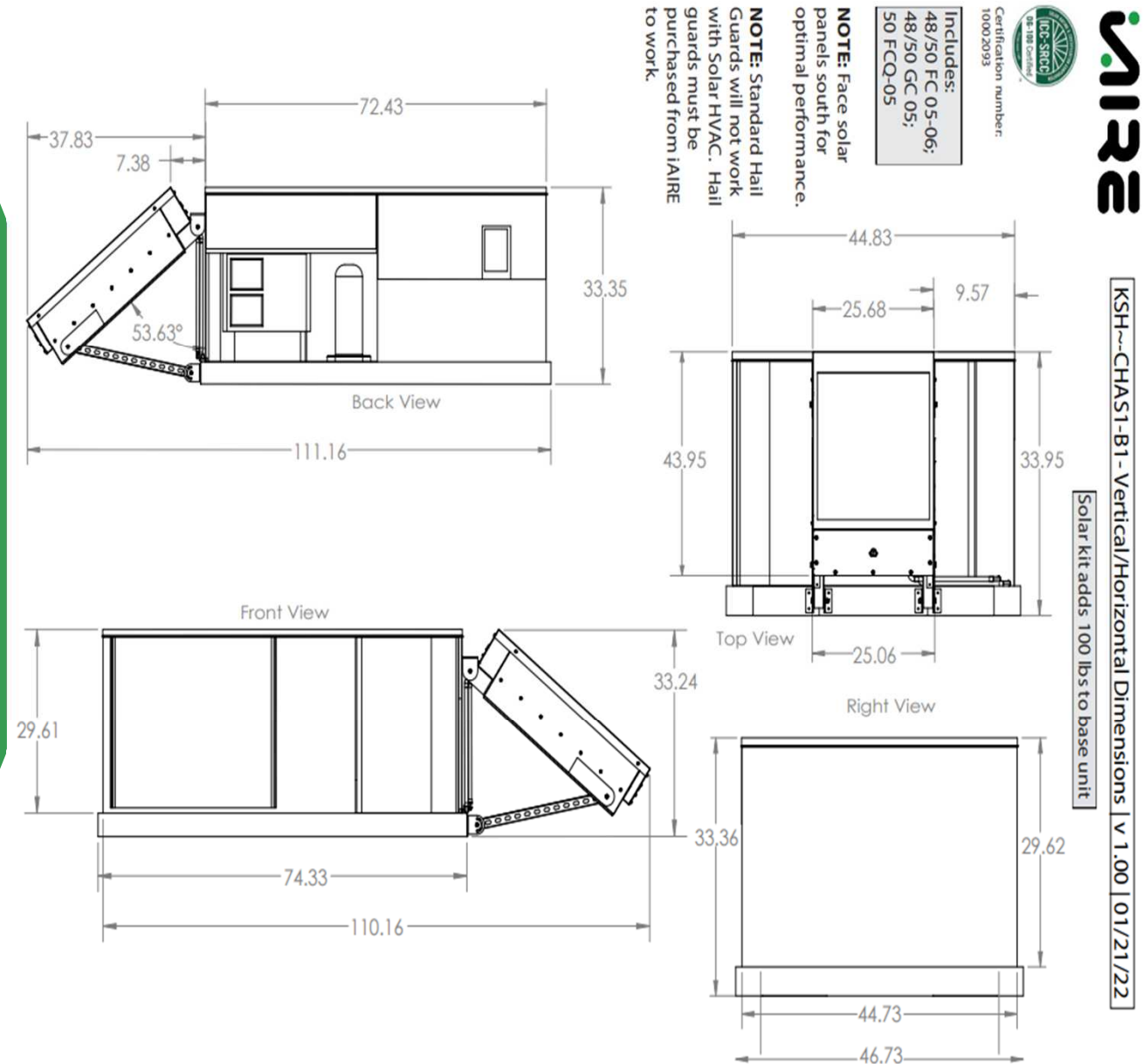



## Going to Market

---

- We will look at (3) scenarios of utilizing Solar HVAC in lieu of utilizing standard equipment
  - 5-ton replacement unit
  - Belmont at Tipton Lakes Facility
    - Senior living facility in Indiana
  - 20-ton DOAS unit



# 5-ton RTU Swap out comparison

| <b>Conventional 5-ton system</b>                                   | <b>Year 1</b>      | <b>Year 2</b>     | <b>Year 3</b>     | <b>Year 4</b>     | <b>Year 5</b>     | <b>Year 6</b>     | <b>Year 7</b>     | <b>Total</b>       |
|--------------------------------------------------------------------|--------------------|-------------------|-------------------|-------------------|-------------------|-------------------|-------------------|--------------------|
| Cost (\$1800/ton)                                                  | \$9,000.00         | \$0.00            | \$0.00            | \$0.00            | \$0.00            | \$0.00            | \$0.00            | \$9,000.00         |
| Federal Credit @40%                                                | \$0.00             | \$0.00            | \$0.00            | \$0.00            | \$0.00            | \$0.00            | \$0.00            | \$0.00             |
| Tax savings on Depreciation expense 15% @21% rate                  | \$283.50           | \$283.50          | \$283.50          | \$283.50          | \$283.50          | \$283.50          | \$283.50          | \$1,984.50         |
| Sales Tax 6%                                                       | \$540.00           | \$0.00            | \$0.00            | \$0.00            | \$0.00            | \$0.00            | \$0.00            | \$540.00           |
| Property tax 1%                                                    | \$90.00            | \$90.00           | \$90.00           | \$90.00           | \$90.00           | \$90.00           | \$90.00           | \$630.00           |
| Electrical cost (\$378/mo)                                         | \$4,536.00         | \$4,989.60        | \$5,488.56        | \$6,037.42        | \$6,641.16        | \$7,305.27        | \$8,035.80        | \$43,033.81        |
| <b>Total yearly cost</b>                                           | <b>\$13,882.50</b> | <b>\$4,796.10</b> | <b>\$5,295.06</b> | <b>\$5,843.92</b> | <b>\$6,447.66</b> | <b>\$7,111.77</b> | <b>\$7,842.30</b> | <b>\$51,219.31</b> |
|                                                                    |                    |                   |                   |                   |                   |                   |                   |                    |
| <b>iAIRE Solar 5-ton system</b>                                    | <b>Year 1</b>      | <b>Year 2</b>     | <b>Year 3</b>     | <b>Year 4</b>     | <b>Year 5</b>     | <b>Year 6</b>     | <b>Year 7</b>     | <b>Total</b>       |
| Plant Install Solar HVAC on above 5-ton RTU                        | \$20,330.95        | \$0.00            | \$0.00            | \$0.00            | \$0.00            | \$0.00            | \$0.00            | \$20,330.95        |
| Federal Credit @40%                                                | \$8,132.38         | \$0.00            | \$0.00            | \$0.00            | \$0.00            | \$0.00            | \$0.00            | \$8,132.38         |
| Tax savings on Depreciation expense 80% yr 1 @21% rate             | \$3,415.60         | \$142.32          | \$142.32          | \$142.32          | \$142.32          | \$142.32          | \$142.32          | \$4,269.50         |
| Sales Tax 6%                                                       | \$0.00             | \$0.00            | \$0.00            | \$0.00            | \$0.00            | \$0.00            | \$0.00            | \$0.00             |
| Property tax 1%                                                    | \$0.00             | \$0.00            | \$0.00            | \$0.00            | \$0.00            | \$0.00            | \$0.00            | \$0.00             |
| Electrical cost (\$260/mo)                                         | \$3,120.00         | \$3,432.00        | \$3,775.20        | \$4,152.72        | \$4,567.99        | \$5,024.79        | \$5,527.27        | \$29,599.97        |
| <b>Total yearly cost</b>                                           | <b>\$11,902.97</b> | <b>\$3,289.68</b> | <b>\$3,632.88</b> | <b>\$4,010.40</b> | <b>\$4,425.68</b> | <b>\$4,882.47</b> | <b>\$5,384.95</b> | <b>\$37,529.04</b> |
|                                                                    |                    |                   |                   |                   |                   |                   |                   |                    |
| <b>Annual Savings with Solar HVAC</b>                              | <b>\$1,979.53</b>  | <b>\$1,506.42</b> | <b>\$1,662.18</b> | <b>\$1,833.51</b> | <b>\$2,021.98</b> | <b>\$2,229.30</b> | <b>\$2,457.35</b> | <b>\$13,690.26</b> |
|                                                                    |                    |                   |                   |                   |                   |                   |                   |                    |
| <b>Assumptions</b>                                                 |                    |                   |                   |                   |                   |                   |                   |                    |
| Utility costs increase 10% per year                                |                    |                   |                   |                   |                   |                   |                   |                    |
| State has no sales tax on approved solar projects                  |                    |                   |                   |                   |                   |                   |                   |                    |
| Customer depreciates equipment over 7 years                        |                    |                   |                   |                   |                   |                   |                   |                    |
| Customer Federal Tax rate is 21%                                   |                    |                   |                   |                   |                   |                   |                   |                    |
| Customer averages 1% payment on property tax                       |                    |                   |                   |                   |                   |                   |                   |                    |
| Federal Tax Credit is 40% on entire installation cost              |                    |                   |                   |                   |                   |                   |                   |                    |
| No other state, local or utility company rebates included          |                    |                   |                   |                   |                   |                   |                   |                    |
| Customer replaced existing 5-ton unit with a 5-ton Solar HVAC unit |                    |                   |                   |                   |                   |                   |                   |                    |



# (92) 2-ton Unit Apartment replacement in 2022

| <b>System as currently designed</b>                             | <b>Year 1</b>      | <b>Year 2</b>      | <b>Year 3</b>      | <b>Year 4</b>      | <b>Year 5</b>      | <b>Year 6</b>      | <b>Year 7</b>      | <b>Total</b>        |
|-----------------------------------------------------------------|--------------------|--------------------|--------------------|--------------------|--------------------|--------------------|--------------------|---------------------|
| Cost                                                            | \$546,618.00       | \$0.00             | \$0.00             | \$0.00             | \$0.00             | \$0.00             | \$0.00             | \$546,618.00        |
| Federal Credit @40%                                             | \$0.00             | \$0.00             | \$0.00             | \$0.00             | \$0.00             | \$0.00             | \$0.00             | \$0.00              |
| Tax savings on Depreciation expense 15% @21% rate               | \$16,398.54        | \$16,398.54        | \$16,398.54        | \$16,398.54        | \$16,398.54        | \$16,398.54        | \$16,398.54        | \$114,789.78        |
| Sales Tax                                                       | \$16,398.54        | \$0.00             | \$0.00             | \$0.00             | \$0.00             | \$0.00             | \$0.00             | \$16,398.54         |
| Property tax 1%                                                 | \$5,466.18         | \$5,466.18         | \$5,466.18         | \$5,466.18         | \$5,466.18         | \$5,466.18         | \$5,466.18         | \$38,263.26         |
| Electrical savings                                              | \$0.00             | \$0.00             | \$0.00             | \$0.00             | \$0.00             | \$0.00             | \$0.00             | \$0.00              |
| Total yearly cost                                               | \$552,084.18       | -\$10,932.36       | -\$10,932.36       | -\$10,932.36       | -\$10,932.36       | -\$10,932.36       | -\$10,932.36       | \$486,490.02        |
|                                                                 |                    |                    |                    |                    |                    |                    |                    |                     |
|                                                                 |                    |                    |                    |                    |                    |                    |                    |                     |
| <b>System with Solar HVAC</b>                                   | <b>Year 1</b>      | <b>Year 2</b>      | <b>Year 3</b>      | <b>Year 4</b>      | <b>Year 5</b>      | <b>Year 6</b>      | <b>Year 7</b>      | <b>Total</b>        |
| Cost including Solar HVAC                                       | \$1,116,254.40     | \$0.00             | \$0.00             | \$0.00             | \$0.00             | \$0.00             | \$0.00             | \$1,116,254.40      |
| Federal Credit @40%                                             | \$446,501.76       | \$0.00             | \$0.00             | \$0.00             | \$0.00             | \$0.00             | \$0.00             | \$446,501.76        |
| Tax savings on Depreciation expense 80% yr 1 @21% rate          | \$187,530.74       | \$7,813.78         | \$7,813.78         | \$7,813.78         | \$7,813.78         | \$7,813.78         | \$7,813.78         | \$234,413.42        |
| Sales Tax                                                       | \$53,580.21        | \$0.00             | \$0.00             | \$0.00             | \$0.00             | \$0.00             | \$0.00             | \$53,580.21         |
| Property tax 1%                                                 | \$0.00             | \$0.00             | \$0.00             | \$0.00             | \$0.00             | \$0.00             | \$0.00             | \$0.00              |
| Electrical savings                                              | \$16,560.00        | \$18,216.00        | \$20,037.60        | \$22,041.36        | \$24,245.50        | \$26,670.05        | \$29,337.05        | \$157,107.55        |
| Total yearly cost                                               | \$519,242.11       | -\$26,029.78       | -\$27,851.38       | -\$29,855.14       | -\$32,059.28       | -\$34,483.83       | -\$37,150.83       | \$331,811.88        |
|                                                                 |                    |                    |                    |                    |                    |                    |                    |                     |
|                                                                 |                    |                    |                    |                    |                    |                    |                    |                     |
| <b>Annual Savings with Solar HVAC</b>                           | <b>\$32,842.07</b> | <b>\$15,097.42</b> | <b>\$16,919.02</b> | <b>\$18,922.78</b> | <b>\$21,126.92</b> | <b>\$23,551.47</b> | <b>\$26,218.47</b> | <b>\$154,678.14</b> |
|                                                                 |                    |                    |                    |                    |                    |                    |                    |                     |
|                                                                 |                    |                    |                    |                    |                    |                    |                    |                     |
| <b>Assumptions</b>                                              |                    |                    |                    |                    |                    |                    |                    |                     |
| Utility costs increase 10% per year                             |                    |                    |                    |                    |                    |                    |                    |                     |
| Customer depreciates equipment over 7 years                     |                    |                    |                    |                    |                    |                    |                    |                     |
| Customer Federal Tax rate is 21%                                |                    |                    |                    |                    |                    |                    |                    |                     |
| Customer averages 1% payment on property tax                    |                    |                    |                    |                    |                    |                    |                    |                     |
| Federal Tax Credit is 40%                                       |                    |                    |                    |                    |                    |                    |                    |                     |
| No other state, local or utility company rebates included       |                    |                    |                    |                    |                    |                    |                    |                     |
| Customer utilizes Solar HVAC in lieu of standard HVAC equipment |                    |                    |                    |                    |                    |                    |                    |                     |
| Cost of equipment and install of Non-Solar HVAC                 | \$ 546,618         |                    |                    |                    |                    |                    |                    |                     |
| Cost of equipment and install of Solar HVAC                     | \$ 1,116,254       |                    |                    |                    |                    |                    |                    |                     |



# (92) 2-ton Unit Apartment replacement in 2023

| <u>System as currently designed</u>                             | <u>Year 1</u>  | <u>Year 2</u> | <u>Year 3</u> | <u>Year 4</u> | <u>Year 5</u> | <u>Year 6</u> | <u>Year 7</u> | <u>Total</u>   |
|-----------------------------------------------------------------|----------------|---------------|---------------|---------------|---------------|---------------|---------------|----------------|
| Cost                                                            | \$546,618.00   | \$0.00        | \$0.00        | \$0.00        | \$0.00        | \$0.00        | \$0.00        | \$546,618.00   |
| Federal Credit @40%                                             | \$0.00         | \$0.00        | \$0.00        | \$0.00        | \$0.00        | \$0.00        | \$0.00        | \$0.00         |
| Tax savings on Depreciation expense 15% @21% rate               | \$16,398.54    | \$16,398.54   | \$16,398.54   | \$16,398.54   | \$16,398.54   | \$16,398.54   | \$16,398.54   | \$114,789.78   |
| Federal rebate                                                  | \$0.00         | \$0.00        | \$0.00        | \$0.00        | \$0.00        | \$0.00        | \$0.00        | \$0.00         |
| Sales Tax                                                       | \$16,398.54    | \$0.00        | \$0.00        | \$0.00        | \$0.00        | \$0.00        | \$0.00        | \$16,398.54    |
| Property tax 1%                                                 | \$5,466.18     | \$5,466.18    | \$5,466.18    | \$5,466.18    | \$5,466.18    | \$5,466.18    | \$5,466.18    | \$38,263.26    |
| Electrical savings                                              | \$0.00         | \$0.00        | \$0.00        | \$0.00        | \$0.00        | \$0.00        | \$0.00        | \$0.00         |
| Total yearly cost                                               | \$552,084.18   | -\$10,932.36  | -\$10,932.36  | -\$10,932.36  | -\$10,932.36  | -\$10,932.36  | -\$10,932.36  | \$486,490.02   |
| <b>System with Solar HVAC</b>                                   |                |               |               |               |               |               |               |                |
| <u>System with Solar HVAC</u>                                   | <u>Year 1</u>  | <u>Year 2</u> | <u>Year 3</u> | <u>Year 4</u> | <u>Year 5</u> | <u>Year 6</u> | <u>Year 7</u> | <u>Total</u>   |
| Cost including Solar HVAC                                       | \$1,116,254.40 | \$0.00        | \$0.00        | \$0.00        | \$0.00        | \$0.00        | \$0.00        | \$1,116,254.40 |
| Federal Credit @40%                                             | \$446,501.76   | \$0.00        | \$0.00        | \$0.00        | \$0.00        | \$0.00        | \$0.00        | \$446,501.76   |
| Tax savings on Depreciation expense 80% yr 1 @21% rate          | \$187,530.74   | \$7,813.78    | \$7,813.78    | \$7,813.78    | \$7,813.78    | \$7,813.78    | \$7,813.78    | \$234,413.42   |
| Federal rebate                                                  | \$446,501.76   | \$0.00        | \$0.00        | \$0.00        | \$0.00        | \$0.00        | \$0.00        | \$446,501.76   |
| Sales Tax                                                       | \$53,580.21    | \$0.00        | \$0.00        | \$0.00        | \$0.00        | \$0.00        | \$0.00        | \$53,580.21    |
| Property tax 1%                                                 | \$0.00         | \$0.00        | \$0.00        | \$0.00        | \$0.00        | \$0.00        | \$0.00        | \$0.00         |
| Electrical savings                                              | \$16,560.00    | \$18,216.00   | \$20,037.60   | \$22,041.36   | \$24,245.50   | \$26,670.05   | \$29,337.05   | \$157,107.55   |
| Total yearly cost                                               | \$72,740.35    | -\$26,029.78  | -\$27,851.38  | -\$29,855.14  | -\$32,059.28  | -\$34,483.83  | -\$37,150.83  | -\$114,689.88  |
| <b>Annual Savings with Solar HVAC</b>                           | \$479,343.83   | \$15,097.42   | \$16,919.02   | \$18,922.78   | \$21,126.92   | \$23,551.47   | \$26,218.47   | \$601,179.90   |
| <b>Assumptions</b>                                              |                |               |               |               |               |               |               |                |
| Utility costs increase 10% per year                             |                |               |               |               |               |               |               |                |
| Customer depreciates equipment over 7 years                     |                |               |               |               |               |               |               |                |
| Customer Federal Tax rate is 21%                                |                |               |               |               |               |               |               |                |
| Customer averages 1% payment on property tax                    |                |               |               |               |               |               |               |                |
| Federal Tax Credit is 40%                                       |                |               |               |               |               |               |               |                |
| Federal rebate is 50% of cost up to \$8000                      |                |               |               |               |               |               |               |                |
| No other state, local or utility company rebates included       |                |               |               |               |               |               |               |                |
| Customer utilizes Solar HVAC in lieu of standard HVAC equipment |                |               |               |               |               |               |               |                |
| Cost of equipment and install of Non-Solar HVAC                 | \$ 546,618     |               |               |               |               |               |               |                |
| Cost of equipment and install of Solar HVAC                     | \$ 1,116,254   |               |               |               |               |               |               |                |



# DOAS standard versus Solar

- 20-ton ultraDRY in Orlando, FL
- Mark-ups
  - 35% distributor
  - 30% contractor
  - A national account might not have either of these mark-ups in cost
- Utility savings of 60,000 KWH
- 40% Federal tax credit
- Shows no sales tax
- Owner could depreciate the other 80% cost in year 1
- Potentially state and local incentives



|                                              | ultraDRY    | ultraDRY Solar |
|----------------------------------------------|-------------|----------------|
| 20 ton ultraDRY                              | \$42,086.00 | \$ 42,086.00   |
| Curb                                         | \$ 1,000.00 | \$ 1,000.00    |
| Electrical install                           | \$ 3,000.00 | \$ 3,000.00    |
| Mechanical Install                           | \$ 4,000.00 | \$ 4,000.00    |
| Solar HVAC Mod                               |             | \$ 22,475.00   |
| Distribution Mark up of Mod                  | \$14,730.10 | \$ 22,596.35   |
| Mechanical Mark up                           | \$19,444.83 | \$ 28,547.21   |
| Customer \$                                  | \$84,260.93 | \$ 123,704.56  |
| Sales Tax                                    | \$ 5,055.66 |                |
| Base Customer Number                         | \$89,316.59 | \$ 123,704.56  |
| % of Base Pricing                            | 100%        | 139%           |
| Additional Cost to Customer over baseline    | \$ -        | \$ 34,387.97   |
| Federal 40% Tax Credit                       | \$ -        | \$ 49,481.82   |
| State/Local Rebates                          |             |                |
| Cost to Customer less Tax Credit             | \$89,316.59 | \$ 74,222.73   |
| % of New total Cost to Customer              | 100%        | 83%            |
| Additional Cost to Customer after tax credit | \$ -        | \$ (15,093.85) |
| Utility Savings @ \$0.10/KWH                 | \$ -        | \$ 6,000.00    |
| Cost to Customer 1st Year operation          | \$89,316.59 | \$ 68,222.73   |
| % of New total Cost to Customer              | 100%        | 76%            |
| Additional Cost to Customer after 1st year   | \$ -        | \$ (21,093.85) |
| Years to Payback                             |             | -2.52          |



Questions?